

MORMUGAO PORT AUTHORITY
Marine Department

Single-cover Quotation no. **DC/SE(M)/71/06/2022** issued on **02.06.2022**



SINGLE-COVER QUOTATION FOR

“Shore Lay-Up of Pilot Launch ‘ML-Shingle’ at Mormugao Port Authority”

Submission at **15.00 hrs** on **20.06.2022**

Website: www.mptgoa.gov.in

MORMUGAO PORT AUTHORITY
MARINE DEPARTMENT, SE[M]-Section

Sealed quotations in **Single-cover** are invited in a sealed cover duly super scribed as

Quotation for: “Shore Lay-Up of Pilot Launch ‘ML-Shingle’ at Mormugao Port Authority”

Quotation invited by	Deputy Conservator, Marine department, MORMUGAO PORT AUTHORITY
Name of Work	Shore Lay-Up of Pilot Launch ‘ML-Shingle’ at Mormugao Port Authority
Quotation no	DC/SE(M)/71/06/2022
Security Deposit	3% of the contract value plus GST of 18% as per, clause No. 5.12.
Completion Period	The work should be completed within 15 days from the 7 th day of receipt of LOA/P.O whichever is earlier.
Liquidated Damages	The contractor shall pay the Board as Liquidated Damages for delay to complete the work, a sum of 0.5% per week or part thereof of the total contract price subject to a maximum of 5% of the total contract price and the Board shall have the power to deduct this amount from the payment of the amounts due to the contractor or from his deposit.
Date & time of Pre Bid Queries	Submission of pre bid queries by 07.06.2022 by 17:00 Hrs. by e-mail on hm@mptgoa.gov.in . Necessary Corrigendum/ Addendum will be made based on Pre-bid queries/subsequently observed and published in Port Website and this shall be a part of Tender Document.
Payment terms	100% payment / month shall be made within 30 days after satisfactory completion of work on producing undisputed- hard copy or digitally signed invoice complete. The contractor shall furnish their bank account number, PAN card, MICR number, name of the Branch along with Bill for arranging payment made through ECS by the MPA.
Bid validity	120 days from date-of-opening of quotation.
Date of submission of bids	20-06-2022 till 15:00 Hrs.
Date of Opening of bids	20-06-2022 at 15:30 Hrs
Address for communication & submission of bid	Deputy Conservator, Marine department, 1 st floor, AO Bldg, Headland Sada, Mormugao Port Authority, Mormugao, Goa – 403804. <i>(Clearly writing tender-no work-title and submission / opening date on outside envelope)</i>
Contact Details	Phone :0832-2594816 / 0832-2594804 E-mail: dc@mptgoa.gov.in , hm@mptgoa.gov.in
Website	www.mptgoa.gov.in
Enclosures [Total 7-pages]	Annexure - A [Scope-of-work] Annexure - B [Terms & conditions] Annexure– C [Bid Security Declaration Form, Price cover and Undertaking letter]

Scope-of-work

1.0 GENERAL

Mormugao Port Authority invites tender in Single cover system for the work of “**Shore Lay-Up of Pilot Launch ‘ML-Shingle’ at Mormugao Port Authority**”

2 SCOPE OF WORK (SERVICES REQUIRED)

2.1 DESCRIPTION OF ML-SHINGLE

Year of Build	2008
Port of Registry	Chennai
Official No	3583
Light Ship	32.32T
Gross Tonnage	48
Net Tonnage	16
Overall Length	17.15 m
Breadth	5.20 m
Depth(MLD)	2.50 m
Draught (MLD)	1.18 m

2.2 METEROLOGICAL DATA OF MORMUGAO PORT:

- i) Current – Current outside sheltered water is about 1 knot current strength 30-40M/sec.
- ii) Tide Variation -The main tide variation is 1.6 mtrs. aspiring tide and 0.7 mtr. as neap tide.
- iii) Depth of navigation channel is 14.4-14.7 mtrs. and inner channel is 14.1-14.4 mtrs.

3.1 The bidder/contractor should provide all the required tools, staff, certified/calibrated testing equipments required for Shore Lay-Up of pilot launch ‘ML-Shingle’.

- 1.** Shore docking of pilot ‘ML-Shingle’ to be carried out at MPA berth no 11 Vasco Goa.
- 2.** Lifting equipments includes D-Shackles, belt slings, wire rope slings, Spreader beam/ Lifting beam of required capacities as detailed at sr. no 01 are to be provided by the contractor and should have valid-SWL testing certificate issued by recognized authority.
- 3.** The entire work of Shore Lay-Up of pilot Launch ‘ML-Shingle’ should be in accordance to the requirement/procedure laid down by Dock safety and satisfaction of Chief Engineer, complying with all the safety requirements
- 4.** Approved safety gears shall have to be provided to the personnel by the contractor for the staff engaged.
- 5.** The services required from the contractor includes:
 - i) Arrangement of D-Shackles, belt slings, wire rope slings, Spreader beam/ Lifting beam, and to depute competent workforce required to carryout the entire work.
 - ii) Assembly of D-Shackles, belt slings, wire rope slings, Spreader beam/ Lifting beam in accordance to the requirement of pilot launch ‘ML-Shingle’ for lifting of launch form sea.
 - iii) Shifting of wooden blocks and concrete blocks to secure pilot launch ‘ML-Shingle’ at berth no 11.
 - iv) Disassembling of D-Shackles, belt slings, wire rope slings, Spreader beam/ Lifting beam from pilot launch ‘ML-Shingle’ after shore docking.

3.2 Following services/equipments will be provided by MPA.

1. Harbour mobile crane of 120T capacity
2. Mobile Crane.
3. Wooden blocks and concrete blocks for securing launch

Note: Bidders is advised to visit the site and shall necessarily submit a undertaking letter in format given below indicating, studied the nature and quantum of work involve, and fully acquainted himself with all the various activities directly and indirectly associated in smoothly executing the contract work.



GENERAL ARRANGEMENT PLAN

MAIN PARTICULARS	
LENGTH OVERALL	: 17.15 m
BREADTH (MLD.)	: 5.20 m
DEPTH (MLD.)	: 2.50 m
DRAFT (MLD.)	: 1.18 m
FRAME SPACING	: 500 mm
CREW COMPLEMENT	: 9
SPEED	: 16 knots
MAIN ENGINE	: 2X450 KW

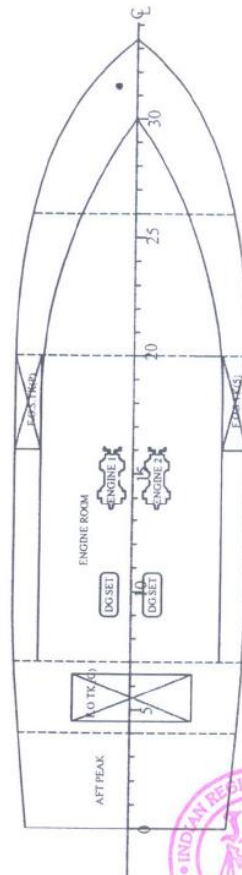
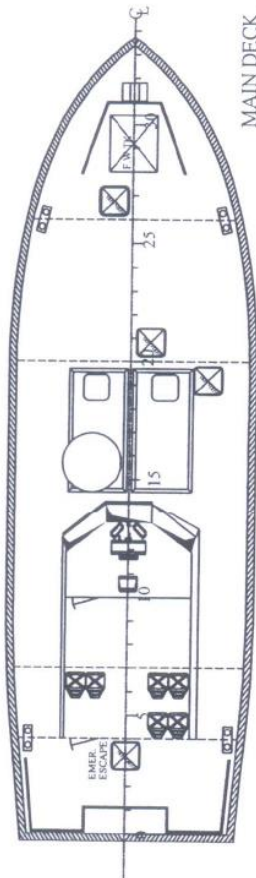
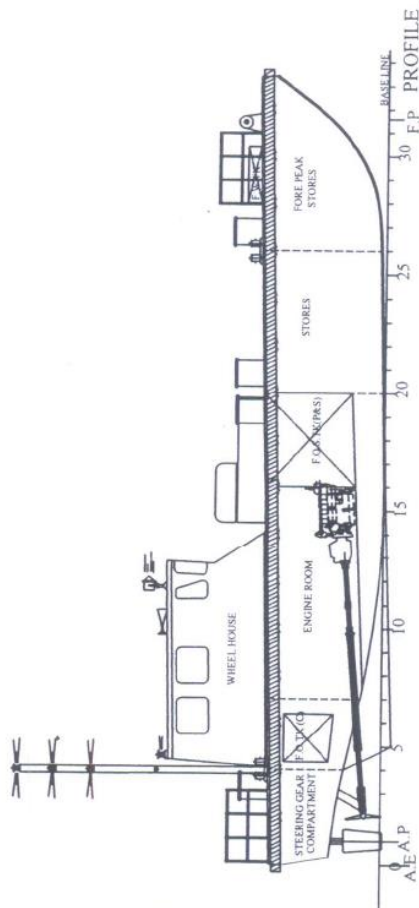

NAVARCH Consultants and Engineers



SUMMARY RESULTS OF ALL LOADING CONDITIONS					
SL. NO	DESCRIPTION	UNIT	LOADING CONDITIONS		
			LC - 1	LC - 2	LC - 3
1	Lightship weight	t	32.32	32.32	32.32
2	Deadweight	t	0.00	6.35	4.64
3	Displacement	t	32.32	38.67	36.97
4	VCG	m	1.74	1.75	1.75
5	LCG	m	7.01	7.06	7.15
6	LCB	m	7.01	7.06	7.15
7	Trim	cm	69.50	64.40	58.80
8	Mean Draft (T)	m	1.07	1.18	1.15
9	LCF	m	6.84	6.93	6.96
10	(MCT _{1cm})	t.m	0.53	0.58	0.57
11	KM _T	m	3.22	3.09	3.12
12	Taft (BASELINE)	m	1.37	1.46	1.41
13	Tfor'd (BASELINE)	m	0.68	0.82	0.83
14	Taft (DRAFT MARKS)	m	1.57	1.66	1.61
15	Tfor'd (DRAFT MARKS)	m	0.57	0.71	0.71
16	GM _T	m	1.48	1.34	1.37
17	GG ₀	m	0.00	0.01	0.01
18	(G ₀ M _T)	m	1.48	1.33	1.36
19	Area upto 30°	m rad	0.18	0.17	0.17
20	Area upto 40°	m rad	0.30	0.28	0.28
21	Area between 30° & 40°	m rad	0.12	0.11	0.11
22	Max (G ₀ Z)	m	0.70	0.64	0.65
23	Angle at Max (G ₀ Z)	deg	40.68	39.66	39.82
24	Angle of heel due to wind (θ ₀)	deg	3.79	3.46	3.67
25	Angle of roll (θ ₁)	deg	25.57	24.51	24.75
26	Gust wind 2nd intercept (θ _c)	deg	>50.00	78.48	78.49
27	Adopted upper limit (θ ₂)	deg	50.00	50.00	50.00
28	Angle of down flooding (θ _f)	deg	59.28	57.95	58.27
29	Angle of deck immersion (θ _d)	deg	30.35	28.44	28.89
30	Area "a"	m rad	0.17	0.14	0.14
31	Area "b"	m rad	0.29	0.29	0.29
32	Max. permissible VCG/KG	m	2.60	2.55	2.57
33	Available VCG/KG	m	1.74	1.75	1.75
34	Min. permissible GoM _T	m	0.62	0.54	0.56
35	Available GoM _T	m	1.48	1.33	1.36

NAVARCH Consultants and Engineers



TERMS AND CONDITIONS

4.0 Submission of Quotation

4.1) The bidder should be submitted Annexure – ‘A’, ‘B’ and ‘C’ in single cover consisting of Scope of Work, Terms and conditions, Bid Security Declaration, price schedule duly signed and stamped and sealed before **20/06/2022 till 15:00** hrs. The cover should be sealed & superscribed as “**Shore Lay-Up of Pilot Launch ‘ML-Shingle’ at Mormugao Port Authority**”

4.2) Bids not sealed properly are summarily rejected.

5.0 GENERAL TERMS AND CONDITIONS

5.1) **Minimum Eligibility Criteria-MEC:** The bidder/contractor should have necessary equipments-tools and experience in lifting of equipments.

The following should accompany the bid document.

- a) The contractor should be experienced contractor who have executed similar works in the last 7 years ending last day of month previous to the one in which quotations are invited. A copy of completion certificate for having executed similar works shall be furnished along with the bid which shall be verified before award of LOA/P.O.
- b) Certificate of Registration with PF Commissioner/ESI authorities and GST.
- c) Price Bid should be duly filled in. Bidders are advised to quote strictly as per the price bid.

“Similar work’ is defined as bidder/contractor should executed for any Govt Organization/PSU/Port/ Harbour/Shipyard or reputed organization.”

5.2. General Conditions

- i) The completion certificates submitted along with the bid shall be verified with the original before award of LOA/P.O
- ii) The bidder shall submit copy of valid GST Registration Certificate, PAN, EPF and ESI registration number. Bidders are advised to quote strictly as per the price bid.

5.3. Validity:

The Bid validity shall be 120 days from the due date of submission of the quotation.

5.4 Price:

The evaluation shall be on the basic price (Total as per Price schedule / BOQ) and shall be considered lowest among all bidders. The rates offered shall be exclusive of GST. If any new tax imposed by the State/Central Govt., same shall be reimbursed by producing documentary proof.

5.5 Earnest Money Deposit:

The bid/ tender shall be accompanied by Bid securing declaration in prescribed format as provided at Annexure II in bid document. The bid/ tender not accompanied with this declaration shall be treated as invalid and shall not be considered.

5.6 Completion Period:

The entire work shall be completed within **15 days** from the 7th day of receipt of LOA/Purchase order whichever is earlier. The contract shall not be assigned or sublet without written prior approval of the Engineer in charge.

5.7 Payment Terms:

- i) 100% payment shall be made within **30 days** after satisfactory completion and upon successful commissioning of the work on furnishing undisputed invoice complete in all respects.
- ii) The contractor shall furnish their bank account details for the payment through ECS. A copy of the PAN card, GST Registration no., wage register, attendance register, EPF& ESI, Bank account number, MICR number, Name of the Branch along with Bills shall be furnished for arranging payment made through E.C.S. by the MPA.
- iii) The bidder shall quote GST No. of MPT (30AAALM0293P1ZY) on all invoices raised on Port. If bidder is not registered under GST or opted for composition scheme under GST, undertaking of the same shall be submitted by the bidder.

5.8 Injury/Damage to persons and property:

- i) The contractor shall take all precautions while carrying out the contract work against any possible damage to Port property. Should any such damage be done by the contractor, he shall make good or bear the cost of making good the same, when brought to his notice, without delay to the satisfaction of the Engineer, failing which the same will be recovered from the bill.
- ii) The contractor shall indemnify the Port against any claim that may arise for any damage to or loss to Port property or injury caused to Port personnel or to any labour engaged by the contractor, during the execution of the contract. The Port will not be responsible for any failure on the part of the contractor or his agent to take necessary measures or precautions in this regard. In this regard contractor will be wholly responsible, if any injury/death of his person on duty, and contractor shall take necessary insurance policy to cover the staff while at work to meet any such eventualities.

5.9 Foreclosure of Contract

Notwithstanding anything in the contract document, the contractor agrees that the Port shall be entitled to foreclose the contract on occurrence of the following events:

- i. In the event of breach of contract by the Contractor
- ii. An emergency or
- iii. for national security and /or national interest and /or public reasons.

Upon the occurrence of the events specified in the above (i),(ii) and (iii)above, the Port reserves the right to fore close the contract at any point of time during the contract period on the issue of the termination notice. The Port shall not be liable to compensate the contractor or any other person for any losses or estimated loss of profits during such period.

5.10 INDEMNIFICATION:

The contractor shall be deemed to indemnify and keep indemnified MPA from and against all actions, claims, demands and liabilities whatsoever under and in respect of the breach of any of the provisions of any law, rules or regulations having the force of law, including but not limited to:-

- a) The Minimum Wages Act, 1948.
- b) The Dock Workers (Regulation of Employment) Act, 1948
- c) The Building And Other Construction Workers (Regulation of Employment & Conditions of Service) Act, 1996
- d) The Dock Workers' Safety, Health & Welfare Act, 1986
- e) The Payment of Wages Act, 1936.
- f) The Workmen's Compensation Act, 1923.
- g) The Employees Provident Fund Act, 1952.
- h) The Contract Labour (Regulation and Abolition) Act, 1970; Rules 1971.
- i) The Payment of Bonus Act, 1965.
- j) The Payment of Gratuity Act, 1972.
- k) The Equal Remuneration Act, 1976.
- l) The Employees State Insurance Act, 1948 & Employees State Insurance (Amendment) Act,1989
- m) Child Labour (Prohibition and Regulation) Act, 1986.
- n) The Maternity Benefits Act 1961.
- o) Interstate Migrant Workmen (Regulation of Employment & Conditions of Service) Act, 1979.
- p) Motor Vehicle Act, latest revision.

5.11 Liquidated Damages:

In the event of failure by the contractor to complete the execution of the work within the time stipulated in the contract or by the expiry of any period of extension granted by the Board's terms thereof, the contractor shall pay the Board as Liquidated Damages for delay to complete the work, a sum of 0.5% per week or part thereof of the total contract price subject to a maximum of 5% of the total contract price and the Board shall have the power to deduct this amount from the payment of the amounts due to the contractor or from his deposit. The GST @18% on LD will be deducted at the time of making payment to Vendors/Contractors.

5.12 SECURITY DEPOSIT(SD):

1. The contractor shall within 07 days from the date of issue of LOA, shall furnish a DD towards Security Deposit equivalent to 3% (three percent) of the contract value plus GST of 18%, rounded off to nearest 100 rupees. The DD shall be from Nationalized/Scheduled Banks in favour of the Financial Advisor & Chief Accounts Officer, MPT, payable at Vasco, Goa.
2. The Board may, at its option, forthwith forfeit the above Security Deposit in whole or part, if in the opinion of the Board the contractor has failed to fulfill any or all of the conditions of this contract without prejudice to any and all rights of the Board to recover from the contractor any amount falling due to the Board through non-observance by the contractor of any of the clause thereof.

6.0 Other terms and conditions

- i)** All tools and tackles and logistics involved in the work shall be arranged by the contractor at their own cost. The transportation cost, if any, shall be borne by the contractor.
- ii)** The scope of work and bill of quantities at “**ANNEXURE-C**” to be read in conjunction to ensure the actual supply and works involved.
- iii)** Necessary Entry passes shall be obtained by the Contractor with prior coordination/ approval of the Port Officials on Duty.
- iv)** The MPA will not be responsible for any loss or damage to the materials/ tools/plants engaged by the contractor/bidder during the work at site or transportation.
- v)** The Contractor shall take utmost care during the execution of the work, if any damage caused to the Port property, the cost of the damage shall be recovered from the Contractor’s running A/c bill or may be recovered by the Board as deemed fit.
- vi)** The power supply shall be provided by the Port free of cost for execution of the work; however, the Contractor shall take power supply from the nearest source by making suitable electrical arrangements such as extension boards, cable, switchgear etc. at their own cost and risk.
- vii)** Any work not mentioned herein above but necessary for overall completion of the work shall be deemed to be included in the scope of work without any additional financial implications to the Port, whatsoever.
- viii)** Under any circumstances, if the work is abandoned by the contractor for whatever reasons, the same shall be executed for successful commissioning ‘thro’ the external agency to be engaged by the Port at the risk and cost of the contractor. The expenditure incurred by the Port in this regards shall be recovered from the monies due to the contractor / security deposit or as deemed fit by the Board.
- ix)** The works shall be carried out with due regard to safety, environment and statutory regulations prevailing at that time.
- x)** All the workmen shall be covered under a suitable insurance policy. Accidents, if any, fatal or otherwise at site shall be the sole responsibility of the contractor. The Port should not be held liable for compensation in whatsoever manner under any circumstances.
- xi)** No labour below the age of 18 years shall be employed. The Contractor shall pay to every employee engaged by him on the work at a rate not less than the minimum rate of wages fixed by the Goa State / Central Govt from time to time under the Minimum Wages Act 1948 and he shall comply with the provision of the said Act and all the prevailing the Rules as applicable on date.
- xii)** The MPT will not be responsible for any loss or damage of the men/materials/tools/plants engaged by the bidder/contractor during the work at site or transportation.
- xiii)** While attending off-shore/afloat-works, the contractor & all his personnel shall compulsorily wear all certified safety gears, life-jackets, anti-skid footwear, goggles, gloves, etc at his cost.
- xiv)** Bidder/contractor shall be fully responsible for safety/security of job/ items at his worksite. Loss due to any damage towards this or bad workmanship shall be suitably recovered as decided by Deputy Conservator/MPT
- xv)** MPT reserves the right to change, alter, modify, add, subtract, increase, decrease, etc the quantities or close tender without giving any justification/reasons to make the contract more feasible.
- xvi)** Address for communication and submission of bid: Deputy Conservator, Office of Deputy Conservator, Marine department, 1st floor, AO Bldg, Headland Sada, Mormugao Port Authority, Mormugao, Goa – 403804. Phone: 0832-2594803 / 2534816
- xvii)** Further amendments if any, visit our Website www.mptgoa.gov.in.

7.0) Bid Security Declaration Form

Date: /06/2022

Quotation no.: DC/SE(M)/71/06/2022

To,

Deputy Conservator,
Marine department, 1st floor,
AO Bldg, Headland Sada,
Mormugao Port Authority,
Mormugao, Goa – 403804.

Sub: Quotation for “Shore Lay-Up of Pilot Launch ‘ML-Shingle’ at Mormugao Port Authority”

I/We. The undersigned, declare that:

I/We understand that, according to tender conditions, bids must be supported by a Bid Securing Declaration.

I/We accept that I/We may be disqualified from bidding for any contract with MPT for a period of one (1) year from the date of notification if I am /We

- a. Are in a breach of any obligation under the bid conditions,
- b. Made misleading or false representations in the forms, statements and attachments submitted.
- c. If the bid is withdrawn or varied or modified in a manner not acceptable to the Employer during the validity or extended validity period duly agreed by the Bidder
- d. Any effort by the Bidder to influence the Employer on bid evaluation, bid comparison or contract award decision.
- e. Fail to commence the work on the specified date as per LOA/Work order and/or.
- f. Furnish the required Security Deposit.

I/We understand this Bid Securing Declaration shall cease to be valid if I am/we are not the successful Bidder, upon the earlier of viz. (i) the receipt of your notification of the name of the successful Bidder; or (ii) thirty days after the expiration of the validity of my/our Bid.

Signed: (insert signature of person whose name and capacity are shown)

in the capacity of (insert legal capacity of person signing the Bid Securing Declaration)

Name: (insert complete name of person signing the Bid Securing Declaration)

Duly authorized to sign the bid for an on behalf of (insert complete name of Bidder)

Dated on _____ day of _____ (insert date of signing)

Corporate Seal (where appropriate)

7.1 PRICE COVER (Bill-of-quantities)

Quotation No.: **DC/SE(M)/71/06/2022** issued on **02.06.2022**

Sr. No	Description	HSN/ SAC No	Qty [AU]	Unit [Rs] price	GST %	GST Amount (Rs.)	Total Amount(Rs.)
Shore Lay-Up of Pilot Launch 'ML-Shingle' at Mormugao Port Authority as detailed at Schedule- 'A' and 'B' including all lifting equipments/Labor/Miscellaneous Charges.							
1	Shore Lay-Up of Pilot Launch 'ML-Shingle' as detailed at scope of work.		01				
Total							

(Rupees _____)

NB: [Valid submitted quotation will be evaluated by comparing total-cost in Price-cover. Annexure-**A** and Annexure-**B** each duly stamped & signed must be submitted along with Price-cover]

I/We agree to carryout **Shore Lay-Up of Pilot Launch 'ML-Shingle'** as specified above in accordance with Scope-of-work (Annexure-A), terms and of the conditions (Annexure – B). The acceptance of this quotation by the Deputy Conservator shall constitute a binding contract between me/us and the Mormugao Port Authority.

Signature and Seal of the Bidder

Name of Firm/Contractor:

Address:

Place:

Date:

7.2) Bidder/Contractor Undertaking Letter

Sub: **Shore Lay-Up of Pilot Launch 'ML-Shingle'**.

1. This is to state that we M/s. _____ Represented by Mr. _____ have read, understood, site-locations, studied various intricacies involved, acquainted ourselves with quantum of work, taken all clarification, etc before submitting the offer. We are required to provided all the relevant facilities & services in complete requirement of subject work as wholesome including those that may be incidental in nature although without specific mention of same thereto.
2. We have read understood, & signed Annexure **A**, **B**, and **C**, in acceptance all tender, Statutory terms/conditions, Standard procedures, relevant compliances, etc as applicable to Government organisations.
3. We ensure and give undertaking that deployed workforce are competent persons with experience in lifting of heavy equipments at shore/offshore and will follow all COVID-19 protocols'.
4. We are fully confidant of executing and delivering the Labour & services involved within the prices quoted at schedule **C**.

Stamped and signed in acceptance

Name of Firm/Contractor:

Address:

Place:

Date: